

Evaluation of Marine Diesel Engine Coolability

Case Study for DAIHATSU DIESEL MFG.CO.,LTD

Using SC/Tetra to analyze the cooling water jacket for marine diesel engine and to evaluate coolability

Diesel Engine DE-18



Product image

The Daihatsu Diesel DE-18 is an economically efficient, next-generation environmentally friendly diesel engine. Having complied with IMO Tier II exhaust emissions requirements while realizing the regulations will continue to tighten in the future, the DE-18 achieves energy-efficiency and low maintenance-costs. The DE-18 takes full advantage of Daihatsu Diesel's proficient experience in developing highly reliable and durable diesel engines.

Design of the cooling water jacket for a diesel engine is a vital part of engine development. Engineers need to generate sufficient cooling effectiveness through highly complicated cooling water passages near the cylinder head. Because the engine is large, prototype tests were extremely difficult and expensive to perform. As an alternative, computational analyses were performed to evaluate product performance.

Comparison between cylinders

Analyses were performed using an all-cylinder model. Differences between each cylinder were noted.

Analysis model



Flow path model of water jacket

Steady-state analysis
Fluid: water
Number of mesh elements: 20 million

Cross section of cylinder inner wall

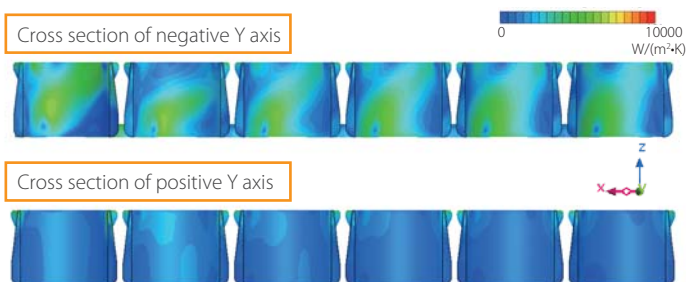

Distribution of heat transfer coefficient on inner wall of cylinder

Deviation in heat transfer distribution between cylinders is small. Predicted values satisfy the requirement.

Comparison between different designs

Analysis results were compared between different designs of components, which are heated during the operation.

Tip of nozzle holder

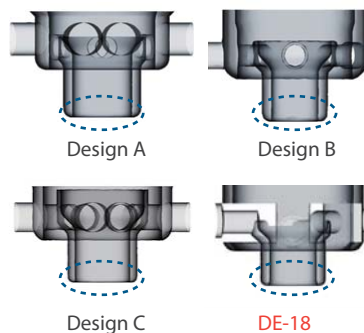

Nozzle holder shapes and holder tip

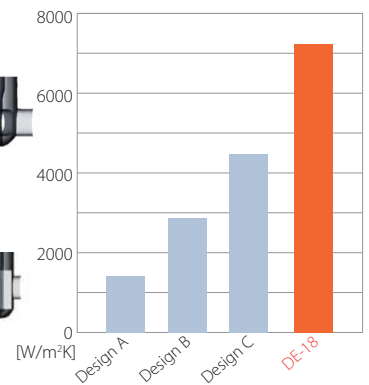

Average heat transfer coefficient of nozzle holder tip

Exhaust valve seat

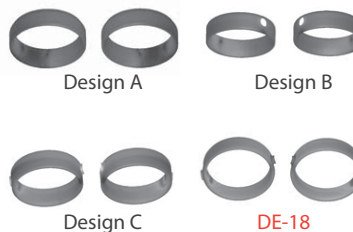

Valve seat shapes

* Different shapes and upstream cooling paths for each type of valve seat

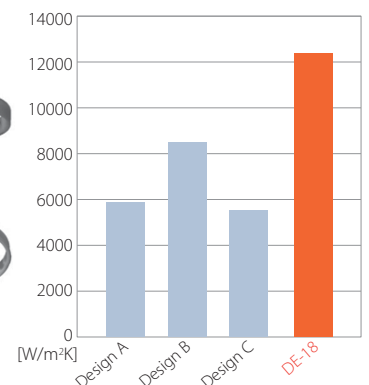

Average heat transfer coefficient of valve seat

Comparison shows that the coolability of the DE-18 is higher than any other designs.

Customer Comments

Applying SC/Tetra to design the water jacket for a marine diesel engine significantly contributed to enhancing coolability and reducing development costs. The large size of a marine engine makes it difficult to perform trial and error tests using the actual product. During development of the DE-18, only one prototype was used. The design was successfully iterated using simulations to predict performance. As a result, both the time needed for the design phase and prototyping costs were drastically reduced.